

# AIR PREPARATION UNITS

## FILTER Series F1

Cat No F1 - 01 - C

### AIR FILTER - 1/4, 3/8, 1/2, 3/4, 1"

#### Features

- Conforms to ISO 5782 -1
- Suitable for Modular mounting
- Steel bowl guard, bayonet type on F14, F15 & F17 models and threaded type on F13 model.
- Press type Manual drain for easy operation.
- Bronze filtering element.
- Separator and shield for efficient moisture separation.



#### Technical Specifications

Model	F13	F14	F15	F17	F17
Medium	Compressed air				
Port size	G1/4	G3/8	G1/2	G3/4	G1
Flow rate (lts / min) <sup>®</sup>	800	2250	3500	5000	6500
Maximum supply pressure (bar)	10				
Ambient / Medium temperature	5° - 50° C				
Filtration # (µm)	1, 5, 25, 40 (standard), 50, 100				
Bowl capacity (ml) (at maximum condensate level)	9	32	44	165	165
Bowl material	Polycarbonate				
Installation	Vertical (as in the picture)				
Materials of construction	Aluminium, Bronze, Steel, Acetal, Polycarbonate, SS, Nitrile				
Optional accessories *	Clamp, Modular mounting kit, Pressure gauge				
Weight (Kg)	0.19	0.32	0.60	1.4	1.3

<sup>®</sup> Supply pressure 6 bar , pressure drop  $\Delta p = 0.3$  bar ( For standard models ).

# For details see " How to order " .

\* For details refer Optional accessories Cat No APA - 01 - C

#### Precautions

1. Note the direction of flow before installation and connect piping accordingly.
2. Flush pipings for dirt, dust, rust and other foreign particles.
3. Install in clean atmosphere.
4. Nipples of taper threads ( R ) to be used with teflon tape. Ensure teflon tape does not enter the unit during tightening. Nipples of straight threads ( G ) to be used with sealing washer.
5. Polycarbonate bowls may get damaged and possibly fail if exposed to synthetic oils, thinner, solvents, trichloroethylene, kerosene or other aromatic hydrocarbons.

# AIR PREPARATION UNITS

## FILTER Series F1

Cat No F1 - 01 - C

**Model F13**

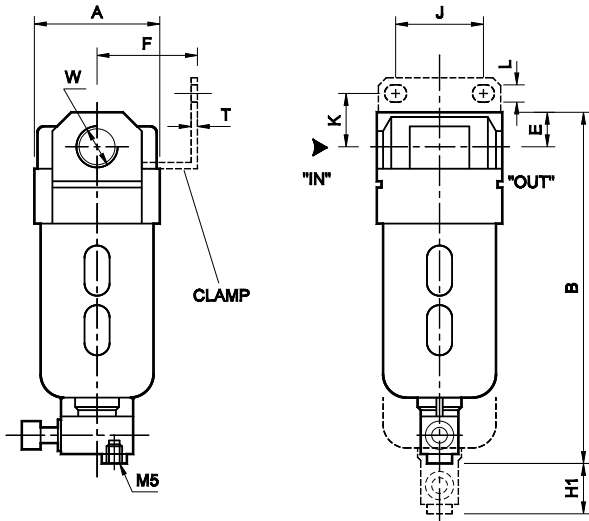

**Model F14 & F15**

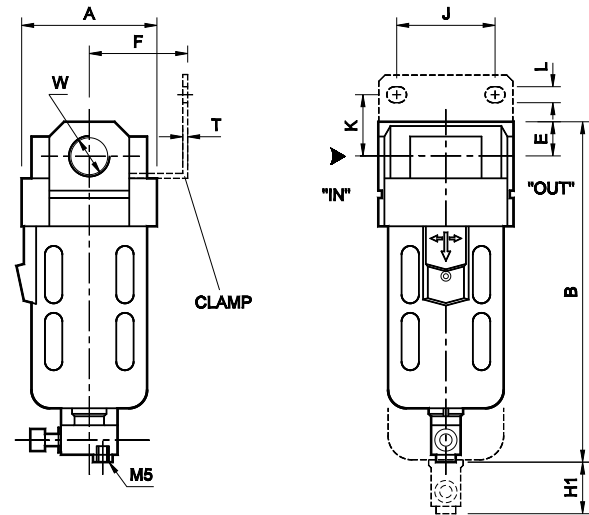

**Model F17**

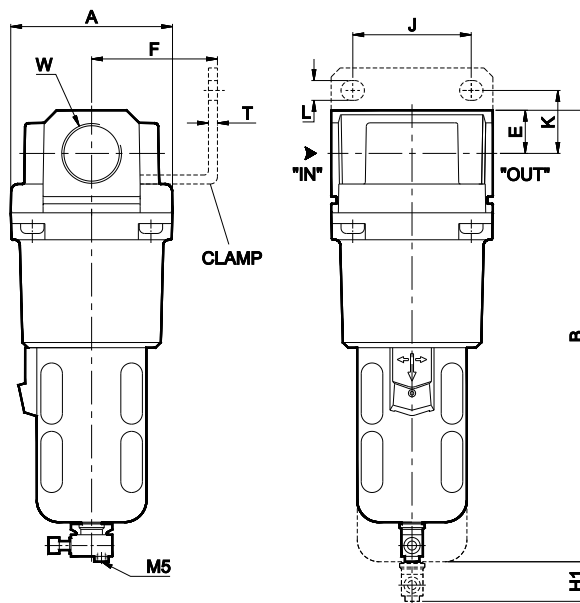

Model	W	A	B	E	K	F	J	L	T	H1
F13	G1/4	SQ 40	113	11	15	30	28	5.5	2	50
F14	G3/8	SQ 55	140	14	25	40	40	6.5	2	55
F15	G1/2	SQ 70	172	18	25	50	55	8.5	2	80
F17	G3/4	SQ 90	260	24	35	70	66	11	5	80
F17	G1	SQ 90	260	24	35	70	66	11	5	80

For Details of Clamp see optional accessories Cat No APA - 01 - C

# AIR PREPARATION UNITS

## FILTER Series F1

Cat No F1 - 01 - C

### Flow Graphs

1/4" FILTER

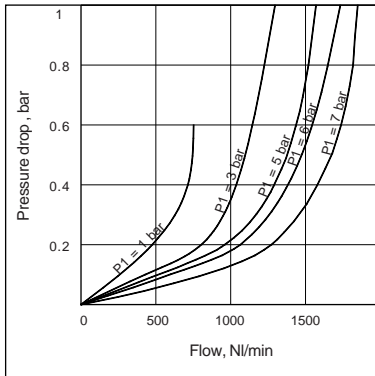

3/8" FILTER

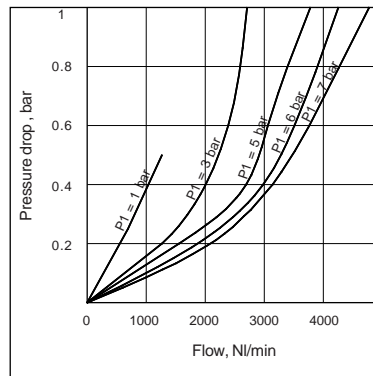

1/2" FILTER

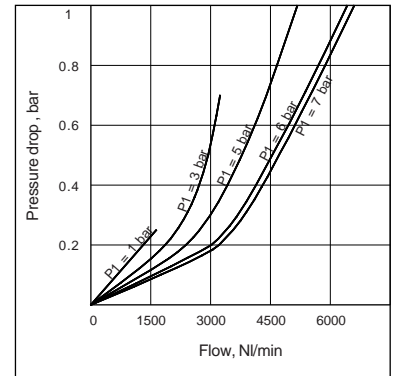

3/4" FILTER

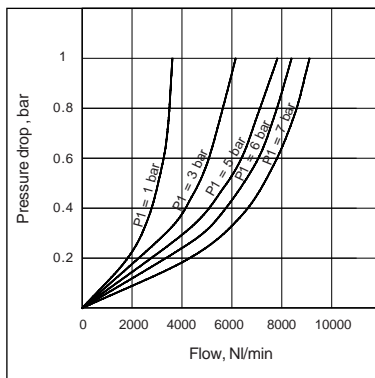

1" FILTER

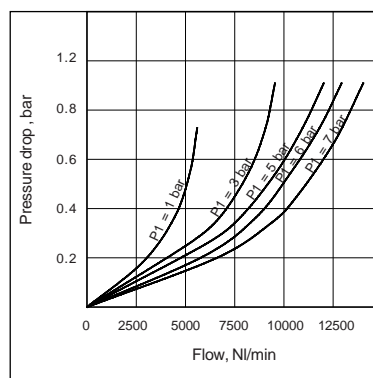

Flow graphs are for 40µm filtrations only

### How to order

F1

Body & Port size	
361	G1/4
462	G3/8
563	G1/2
764	G3/4
765	G1

Filtration in µm	
0	- 1
1	- 5
2	- 25
3	- 40 (Standard)
4	- 50
5	- 100

**Ordering example** :- Filter - 3/8 size ( with G3/8 port ) with 50µm filter : Ordering No: F14624

If ordered as 3/8 Filter, our standard model F14623, with 40µm will be supplied .