



POP® V-Grip blind rivets



POP® V-Grip blind rivets stand out for their large grip range, their large, uniformly-shaped footprint (on the blind side), and their noise-free (anti-rattle) connections. Dustproof and impermeable to splash water.

Benefits at a glance

- Universal use
- Forms a large blind side footprint, very suitable for thin materials
- Anti-rattle due to securely fitting mandrel
- Rolled mandrel, reduced jaw wear and tear
- Chamfered mandrel head for easier installation
- Large grip range, ideal as a multi-purpose blind rivet
- Captive mandrel
- Combines various materials such as metals and plastics
- Available in a wide variety of head shapes
- Quick and secure installation
- Permanent secure fixing
- Heatless installation means component will not warp
- Eliminates extensive refinishing
- Ideal for lightweight constructions

Applications



- Automotive industry
- General industry
- Bodywork and vehicle manufacture



POP® V-Grip blind rivets

Truss head

Material

	
Sleeve	Mandrel
Aluminium AlMg 2.5	Steel, galvanised

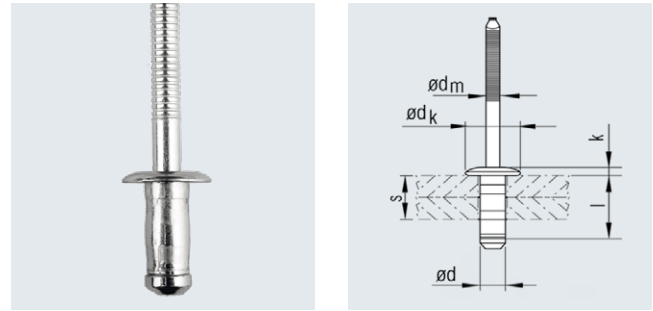

Nominal \varnothing d [mm]	Bore \varnothing [mm]	Grip range s [mm]	Blind sleeve l ±0.5 [mm]	Blind rivet head \varnothing dk ±0.4 [mm]	Height k ±0.3 [mm]	Mandrel \varnothing dm nom. [mm]	Nominal strength at break*		Article No.
							Shear N	Tensile N	
4.8	4.9 - 5.0	1.5 - 6.0	10.6	9.5	1.4	3.1	1200	1900	304 780 000
		6.0 - 10.0	16.2	9.5	1.4	3.1	1200	1900	304 781 001

* Strengths at break relate to rivet failure.

Other designs available on request.

POP® V-Grip blind rivets



Truss head

Material

Sleeve

Steel SAE 1006,
galvanised

Mandrel

Steel,
galvanised

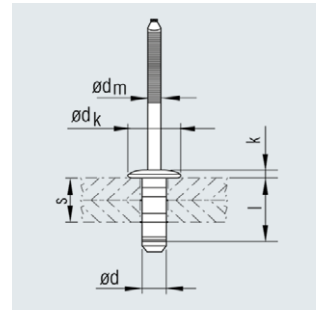

Nominal \varnothing d [mm]	Bore \varnothing [mm]	Grip range s [mm]	Blind sleeve l ± 0.5 [mm]	Blind rivet head \varnothing dk ± 0.4 [mm]	Height k ± 0.3 [mm]	Mandrel \varnothing dm nom. [mm]	Nominal strength at break*		Article No.
							Shear N	Tensile N	
4.8	4.9 - 5.0	1.5 - 6.0	10.6	9.5	1.4	3.1	2800	3600	304 784 000
		6.0 - 10.0	16.2	9.5	1.4	3.1	2600	3300	304 785 000

* Strengths at break relate to rivet failure.

Other designs available on request.



POP® V-Grip blind rivets

Large truss head

Material

Sleeve
Steel SAE 1006,
galvanised

Mandrel
Steel,
galvanised

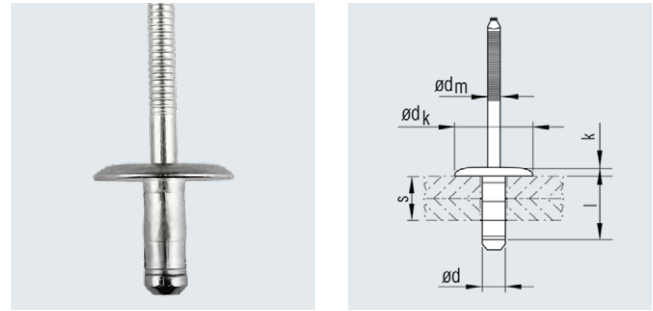

Nominal \varnothing d [mm]	Bore \varnothing [mm]	Grip range s [mm]	Blind sleeve l \pm 0.5 [mm]	Blind rivet head \varnothing dk \pm 0.4 [mm]	Height k \pm 0.3 [mm]	Mandrel \varnothing dm nom. [mm]	Nominal strength at break*		Article No.
							Shear N	Tensile N	
4.8	4.9 - 5.0	1.5 - 6.0	10.6	16	1.9	3.1	2800	3600	304 786 000
		6.0 - 10.0	16.2	16	1.9	3.1	2600	3300	304 787 000

* Strengths at break relate to rivet failure.

Other designs available on request.