



POP® closed end blind rivets



The proven benefits that come with blind rivet technology are becoming recognised and employed by an increasing number of users: for example, in electrical engineering, vehicle construction, medical technology, mechanical engineering, household appliances, energy management, the toy and furniture industries, or even in the automotive and plant engineering sectors. Unlike welded joints, which cause the material to warp, rivets can be quickly installed on one side and with little heat. Even on hollow profiles and pipes, the joints are guaranteed to fit perfectly and maintain their dimensional accuracy.

POP® closed end blind rivets have a cup-shaped sleeve that creates a closed and thus airtight, dust-tight and watertight footprint on the blind side. The high shear bearing resistance of POP® closed end blind rivets makes for a very tight fastening. The mandrel remains securely retained in the sleeve. The stainless steel versions offer high corrosion resistance.





Airtight, dust-tight and watertight footprint

For suitably prepared holes, POP® closed end blind rivets are exceptionally watertight in the field. For pressure-tight applications or retained media, an additional seal will be required between the rivet body and the bored hole in the component. Loose or mechanically fitted neoprene O-rings as well as POP® closed end blind rivets with pre-applied sealant can be supplied on request.

Coloured plastic caps

Plastic caps in an array of RAL colours can be supplied for the POP® closed end blind rivet line.

General building control approval

Some dimensions are available with general building control approval No. Z-14.1-4.

Benefits at a glance

- Quick and secure installation
- Up to 60% cost savings compared to screws or welding (fewer components and faster installation)
- Permanent fastener guards against unauthorised removal.
- Airtight, dust-tight and watertight footprint on the blind side; suitable for watertight and pressure-tight applications
- Optionally available with additional surface coating
- Additional seal under the rivet head available on request
- Universal use
- Captive mandrel
- Heatless installation means component will not warp
- Combines various materials such as metals and plastics
- Eliminates extensive refinishing
- Ideal for lightweight constructions

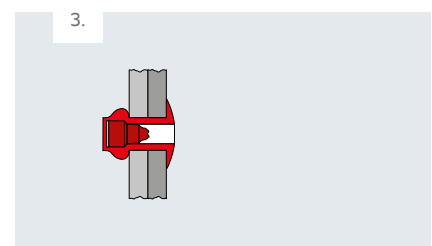
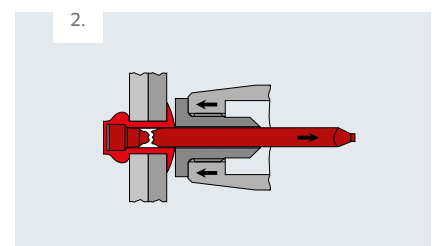
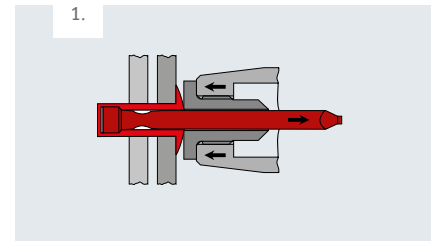

The areas of application and therefore the demand for POP® closed end blind rivets have grown steadily over the past years. This is due to a parallel rise in the demands that the industry is placing on quality and workmanship.

Sample applications:

- General industry
- Marine applications (onshore & offshore, coupled with Tibulb® and M-Lock®)
- Power stations (coupled with Tibulb® and M-Lock®)
- Food industry
- Pharmaceutical industry
- Automotive industry
- Tank and apparatus construction
- Bodywork and vehicle manufacture
- Construction industry



POP® closed end blind rivets

Truss head

Material

■ Sleeve:
Aluminum AlMg5

■ Mandrel:
Steel

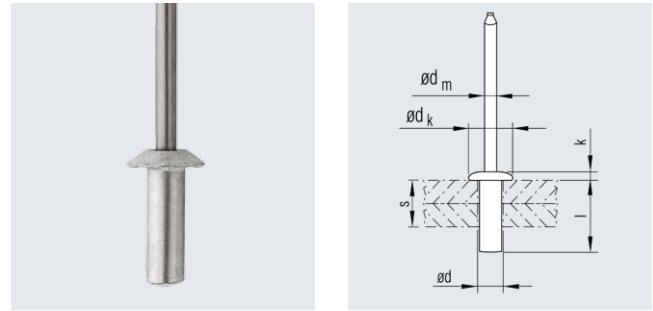

Nominal \varnothing d [mm]	Bore \varnothing [mm]	Grip range s [mm]	Blind sleeve l ± 0.5 [mm]	Blind rivet head		Mandrel \varnothing d _m nom. [mm]	Nominal strength at break		Article No.
				\varnothing dk ± 0.5 [mm]	Height k ± 0.3 [mm]		Shear [N]	Tensile [N]	
3.2	3.3	0.8 - 1.6	6.0	6.0	1.1	1.6	1100	1400	315 629 500
		1.6 - 3.2	7.7	6.0	1.1	1.6	1100	1400	315 630 500
		3.2 - 4.8	9.2	6.0	1.1	1.6	1100	1400	315 631 500
		4.8 - 6.4	10.8	6.0	1.1	1.6	1100	1400	315 632 500
		6.4 - 7.9	12.4	6.6	1.1	1.6	1100	1400	315 633 500
4.0	4.1	1.6 - 3.2	8.0	7.9	1.5	2.2	1600	2220	315 670 500
		3.2 - 4.8	9.6	7.9	1.5	2.2	1600	2220	315 671 500
		4.8 - 6.4	11.2	7.9	1.5	2.2	1600	2220	315 672 500
		6.4 - 7.9	12.8	7.9	1.5	2.2	1600	2220	315 673 500
4.8	4.9	1.6 - 3.2	8.4	9.5	1.8	2.6	2200	3100	315 720 500
		3.2 - 4.8	10.0	9.5	1.8	2.6	2200	3100	315 721 500
		4.8 - 6.4	11.6	9.5	1.8	2.6	2200	3100	315 722 500
		6.4 - 7.9	13.1	9.5	1.8	2.6	2200	3100	315 723 500
		7.9 - 9.5	14.7	9.5	1.8	2.6	2200	3100	315 724 500
		9.5 - 12.7	17.9	9.5	1.8	2.6	2200	3100	315 725 500
		12.7 - 15.9	22.0	9.5	1.8	2.6	2200	3100	315 727 500

* Strengths at break relate to rivet failure.

Other designs available on request.



POP® closed end blind rivets

Countersunk 120°

Material

■ Sleeve:
Aluminum AlMg5

■ Mandrel:
Steel

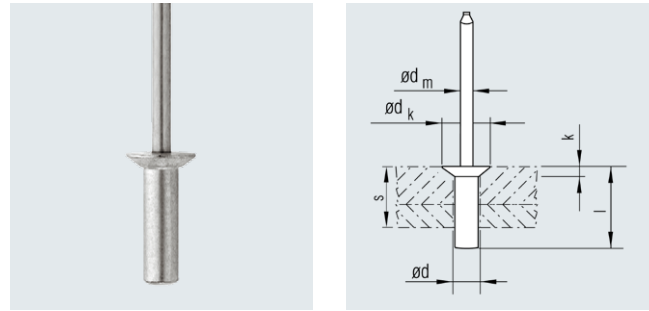

Nominal \varnothing d [mm]	Bore \varnothing [mm]	Grip range s [mm]	Blind sleeve l ± 0.5 [mm]	Blind rivet head		Mandrel \varnothing d _m nom. [mm]	Nominal strength at break		Article No.
				\varnothing dk ± 0.5 [mm]	Height k ± 0.3 [mm]		Shear [N]	Tensile [N]	
3.2	3.3	1.6 - 3.2	8.7	6.0	1.2	1.6	1100	1400	315 639 500
		3.2 - 4.8	10.2	6.0	1.2	1.6	1100	1400	315 640 500
		4.8 - 6.4	11.8	6.0	1.2	1.6	1100	1400	315 641 500
		6.4 - 7.9	13.4	6.0	1.2	1.6	1100	1400	315 642 500
		7.9 - 9.5	15.0	6.0	1.2	1.6	1100	1400	315 643 500
4.0	4.1	3.2 - 4.8	11.0	7.9	1.5	2.2	1600	2220	315 680 500
		4.8 - 6.4	12.6	7.9	1.5	2.2	1600	2220	315 681 500
		6.4 - 7.9	14.2	7.9	1.5	2.2	1600	2200	315 682 500
		7.9 - 9.5	16.0	7.9	1.5	2.2	1600	2220	315 683 500
4.8	4.9	1.6 - 3.2	10.1	9.5	1.8	2.6	2200	3100	315 730 500
		3.2 - 6.4	13.3	9.5	1.8	2.6	2200	3100	315 731 500
		6.4 - 9.5	16.5	9.5	1.8	2.6	2200	3100	315 732 500
		9.5 - 12.7	19.5	9.5	1.8	2.6	2200	3100	315 735 500

* Strengths at break relate to rivet failure.

Other designs available on request.



POP® closed end blind rivets

Truss head

Material

 Sleeve:
Aluminum AlMg5

 Mandrel:
Stainless steel 1.4306

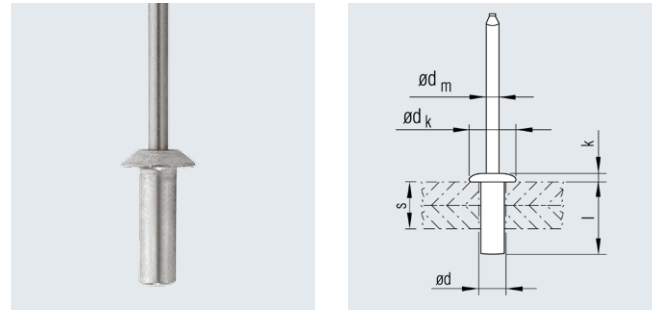

Nominal \varnothing d [mm]	Bore \varnothing [mm]	Grip range s [mm]	Blind sleeve l ± 0.5 [mm]	Blind rivet head		Mandrel \varnothing dm nom. [mm]	Nominal strength at break		Article No.
				\varnothing dk ± 0.5 [mm]	Height k ± 0.3 [mm]		Shear [N]	Tensile [N]	
3.2	3.3	0.5 - 1.6	6.0	6.0	1.2	1.6	1100	1400	319 629 500
		1.6 - 3.2	7.7	6.0	1.2	1.6	1100	1400	319 630 500
		3.2 - 4.8	9.2	6.0	1.2	1.6	1100	1400	319 631 500
		4.8 - 6.4	10.8	6.0	1.2	1.6	1100	1400	319 632 500
		6.4 - 7.9	12.4	6.0	1.2	1.6	1100	1400	319 633 500
4.0	4.1	3.2 - 4.8	9.6	7.9	1.5	2.2	1600	2220	319 671 500
		4.8 - 6.4	11.2	7.9	1.5	2.2	1600	2220	319 672 500
4.8	4.9	0.5 - 3.2	8.4	9.5	1.9	2.6	2200	3100	319 720 500
		3.2 - 4.8	10.0	9.5	1.9	2.6	2200	3100	319 721 500
		4.8 - 6.4	11.6	9.5	1.9	2.6	2200	3100	319 722 500
		6.4 - 7.9	13.1	9.5	1.9	2.6	2200	3100	319 723 500
		7.9 - 9.5	14.7	9.5	1.9	2.6	2200	3100	319 724 500
		9.5 - 12.7	17.9	9.5	1.9	2.6	2200	3100	319 725 500
		12.7 - 15.9	22.0	9.5	1.9	2.6	2200	3100	319 727 500

* Strengths at break relate to rivet failure.

Other designs available on request.



POP® closed end blind rivets

Truss head

Material

Sleeve:
Aluminum AlMg 5

Mandrel:
Aluminum

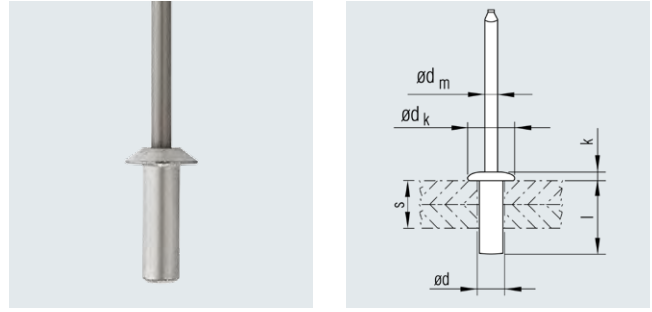

Nominal \varnothing d [mm]	Bore \varnothing [mm]	Grip range s [mm]	Blind sleeve l ± 0.5 [mm]	Blind rivet head		Mandrel \varnothing dm nom. [mm]	Nominal strength at break		Article No.
				\varnothing dk ± 0.5 [mm]	Height k ± 0.3 [mm]		Shear [N]	Tensile [N]	
3.2	3.3	1.6 - 3.2	7.6	6.0	1.1	1.8	460	660	315 860 000
		3.2 - 4.8	9.2	6.0	1.1	1.8	460	660	315 861 000
		4.8 - 6.4	10.8	6.0	1.1	1.8	460	660	315 862 000
4.0	4.1	3.2 - 4.8	9.6	8.0	1.5	2.3	680	1050	315 881 000
		4.8 - 6.4	11.2	8.0	1.5	2.3	680	1050	315 882 000
4.8	4.9	4.8 - 6.4	11.5	9.5	1.8	2.8	960	1300	315 902 000
		7.9 - 9.5	14.7	9.5	1.8	2.8	960	1300	315 904 000
		9.5 - 12.7	17.9	9.5	1.8	2.8	960	1300	315 905 000

* Strengths at break relate to rivet failure.

Other designs available on request.



POP® closed end blind rivets

Truss head

Material

Sleeve:
Steel, galvanised
passivated

Mandrel:
Steel, galvanised

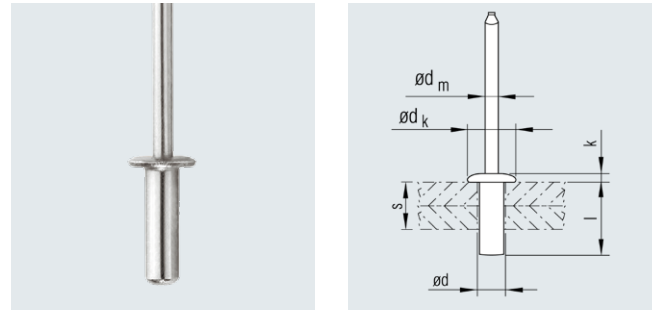

Nominal \varnothing d [mm]	Bore \varnothing [mm]	Grip range s [mm]	Blind sleeve l ± 0.5 [mm]	Blind rivet head		Mandrel \varnothing dm nom. [mm]	Nominal strength at break		Article No.
				\varnothing dk ± 0.5 [mm]	Height k ± 0.2 [mm]		Shear [N]	Tensile [N]	
3.2	3.3	3.2 - 4.8	9.7	6.3	0.9	1.9	1100	1200	315 401 900
4.0	4.1	1.6 - 4.8	10.2	8.0	1.1	2.3	1700	1800	315 421 900
4.8	4.9	0.5 - 3.2	9.2	9.5	1.2	2.9	2400	2800	315 440 900
		4.8 - 6.4	12.4	9.5	1.2	2.9	2400	2800	315 442 900

* Strengths at break relate to rivet failure.

Other designs available on request.



POP® closed end blind rivets

Truss head

Material



Sleeve:
Nickel/copper alloy
70/30, galvanised



Mandrel:
Steel, galvanised

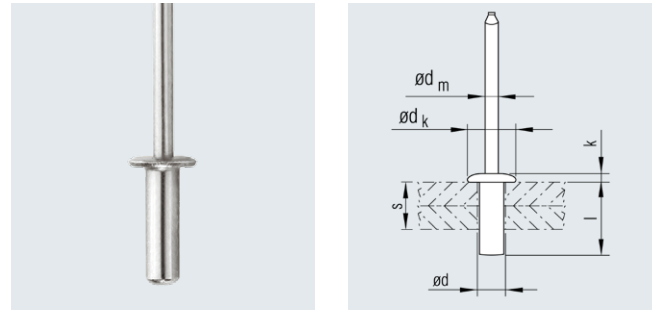

Nominal \varnothing d [mm]	Bore \varnothing [mm]	Grip range s [mm]	Blind sleeve $l \pm 0.5$ [mm]	Blind rivet head		Mandrel \varnothing d_m nom. [mm]	Nominal strength at break		Article No.
				\varnothing $dk \pm 0.5$ [mm]	Height $k \pm 0.2$ [mm]		Shear [N]	Tensile [N]	
3.2	3.3	3.2 - 4.8	9.7	6.3	0.9	1.9	1500	1900	315 101 000
4.0	4.1	3.2 - 4.8	10.2	7.9	1.1	2.3	2200	3000	315 121 000
4.8	4.9	0.5 - 3.2	9.2	9.5	1.2	2.9	3300	3700	315 140 000
		4.8 - 6.4	12.4	9.5	1.2	2.9	3300	3700	315 142 000

* Strengths at break relate to rivet failure.

The 70/30 nickel/copper alloy used in POP® closed end blind rivets is equivalent to Monel®.

POP® closed end blind rivets made of 70/30 nickel/copper alloy are additionally galvanised to further enhance the products' resistance.

Other designs available on request.



POP® closed end blind rivets

Truss head with grooved mandrel

Material

Sleeve:  Mandrel:  
 Stainless steel 1.4303 Stainless steel 1.4006

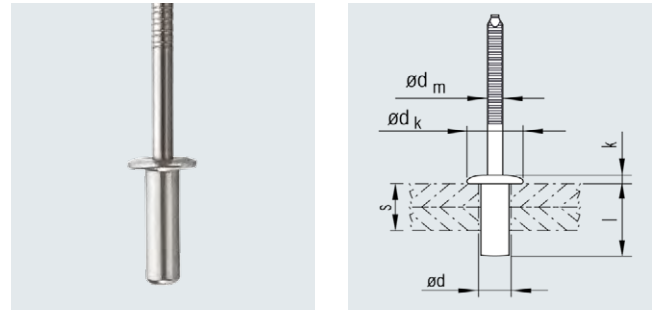

Nominal \varnothing d [mm]	Bore \varnothing [mm]	Grip range s [mm]	Blind sleeve l ± 0.5 [mm]	Blind rivet head		Mandrel \varnothing d _m nom. [mm]	Nominal strength at break		Article No.
				\varnothing dk ± 0.3 [mm]	Height k ± 0.2 [mm]		Shear [N]	Tensile [N]	
3.2	3.3	1.6 - 3.2	8.0	6.5	0.8	1.9	2100	2220	319 400 000
		3.2 - 4.8	9.7	6.5	0.8	1.9	2100	2220	319 401 000
		4.8 - 6.4	11.3	6.5	0.8	1.9	2100	2220	319 402 000
		6.4 - 7.9	12.9	6.5	0.8	1.9	2100	2220	319 403 000
4.0	4.1	0.5 - 3.2	8.6	7.9	0.9	2.4	3300	4000	319 420 000
		3.2 - 4.8	10.2	7.9	0.9	2.4	3300	4000	319 421 000
		4.8 - 6.4	11.8	7.9	0.9	2.4	3300	4000	319 422 000
		6.4 - 7.9	13.4	7.9	0.9	2.4	3300	4000	319 423 000
4.8	4.9	0.5 - 3.2	9.2	9.5	1.1	3.0	4300	4400	319 440 000
		3.2 - 4.8	10.8	9.5	1.1	3.0	4300	4400	319 441 000
		4.8 - 6.4	12.5	9.5	1.1	3.0	4300	4400	319 442 000
		6.4 - 9.5	15.5	9.5	1.1	3.0	4300	4400	319 444 000
		9.5 - 12.7	18.5	9.5	1.1	3.0	4300	4400	319 445 000
6.4	6.5	0.5 - 6.4	14.2	12.7	1.3	3.9	6800	8700	319 460 000
		6.4 - 7.9	15.7	12.7	1.3	3.9	6800	8700	319 461 000
		7.9 - 12.7	20.5	12.7	1.3	3.9	6800	8700	319 462 000

* Strengths at break relate to rivet failure.

Other designs available on request.



POP® closed end special blind rivets

Truss head with grooved mandrel

Material

Sleeve:
 Stainless steel 1.4303

Mandrel:
 Stainless steel 1.4006

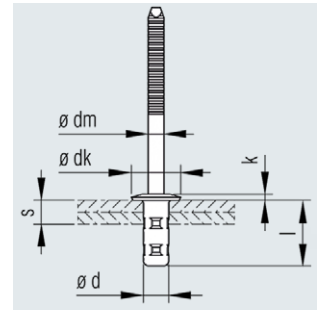

Nominal \varnothing d [mm]	Bore \varnothing [mm]	Grip range s [mm]	Blind sleeve l ± 0.5 [mm]	Blind rivet head		Mandrel \varnothing dm nom. [mm]	Nominal strength at break		Article No.
				\varnothing dk ± 0.5 [mm]	Height k ± 0.2 [mm]		Shear [N]	Tensile [N]	
4.8	5	2.0 - 4.5	12.3	9.3	1.1	3.0	4300	4800	319 451 000
		3.5 - 6.0	13.7	9.3	1.1	3.0	4300	4800	319 452 000
		5.0 - 7.5	15.3	9.3	1.1	3.0	4300	4800	319 455 000
		6.5 - 9.0	16.8	9.3	1.1	3.0	4300	4800	319 453 000
		9.0 - 11.5	19.7	9.3	1.1	3.0	4300	4800	319 454 000

* Strengths at break relate to rivet failure.

Other designs available on request.



Fillers for POP® blind rivets

For sealing and covering the rivet head side of POP® blind rivets with a standard truss head.

Plastic fillers with cap for POP® blind rivets

ø [mm]	Material	Colour	similar to RAL	Filler dim. [mm]	Article No.
3.0 / 3.2	Al alloy	white	9010	8.0 x 2.0 x 1.5	408 360
		black	9011	8.0 x 2.0 x 1.5	408 361
4.8 / 5.0	Steel, stainless steel	white	9010	13.0 x 3.2 x 4.0	408 367
		black	9011	13.0 x 3.2 x 4.0	408 368
		silver	9006	13.0 x 3.2 x 4.0	408 369
	Al alloy	silver	9006	13.0 x 2.6 x 4.0	408 374
		white	9010	13.0 x 2.6 x 4.0	408 380
		black	9011	13.0 x 2.6 x 4.0	408 381

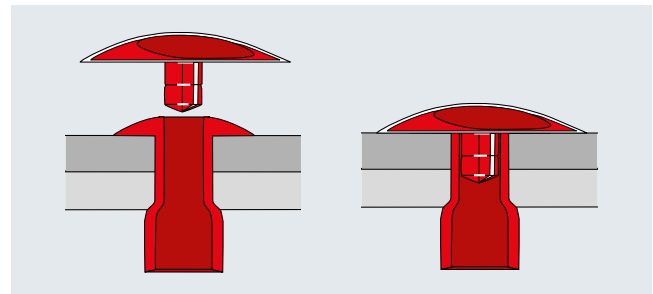

Plastic fillers for POP® blind rivets – standard version

ø [mm]	Material	Colour	Article No.
3.0 / 3.2	Al alloy, steel, stainless steel	white	408 333
4.0	Al alloy, steel, stainless steel	white	408 334
4.8 / 5.0	Steel, stainless steel	white	408 335
	Al alloy	grey	408 341
6.4	Steel	white	408 336

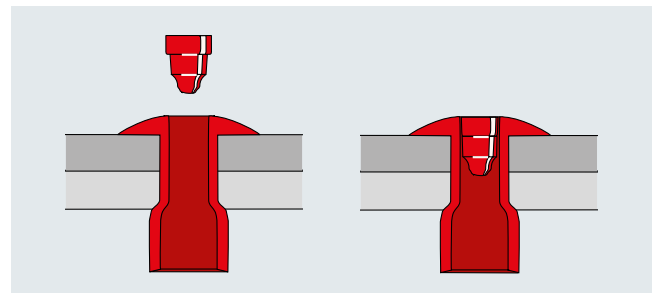

Washers

ø [mm]	Material	Colour	Article No.
Neoprene	6.5 x 3.8 x 1	black	408 235
	10 x 3.5 x 1	black	408 232
	10 x 3.8 x 1	black	408 230
	11 x 6.0 x 1	black	408 146
Brass	12 x 3.3 x 1	-	408 147
	12 x 4.1 x 1	-	408 114
	12 x 4.9 x 1	-	408 148
Steel	9 x 4.3 x 1	galvanized	408 214
	10 x 3.1 x 1	galvanized	408 213
	12 x 3.1 x 1	galvanized	408 203
	12 x 4.1 x 1	galvanized	408 204
	12 x 5.1 x 1	galvanized	408 205
Stainless steel	12 x 4.7 x 1	-	408 100
	12 x 5.0 x 1	-	408 101

