



Series 1370 - 1371 - 1372 - 1373 - ECOFLAT

General

Profiled tube has two "T" slots on the side hosting sensors 1580._, MRS._, MHS._. without adaptors.
Two additional connections are also available on rear cover for cylinder feeding.

Construction characteristics

End caps	aluminium anodised
Rod	C43 chromed steel or stainless steel
Barrel	aluminium alloy anodised
Piston	acetal resin, aluminium on request
Piston-seal	PUR
Rod-seal	PUR (FPM upon request)
Adjusting screw	zinc plated steel
Shock absorber	NBR

Operational characteristics

Fluid	Filtered air. No lubrication needed, if applied it shall be continuous.
Max. pressure	10 bar
Operating temperature	-5°C - +70°C

Please follow the suggestions below to ensure a long life for these cylinders:

- use clean and lubricated air
- correct alignment during assembly with regard to the applied load so as to avoid radial components or bending the rod;
- avoid high speeds together with long strokes and heavy loads: this would produce kinetic energy which the cylinder cannot absorb, especially if used as a limit stop (in this case use mechanical stop device and aluminium piston);
- evaluate the environmental characteristics of cylinder used (high temperature, hard atmosphere, dust, humidity etc.)

Please note: air must be dried for applications with lower temperature.

Use hydraulic oils H class (ISO VG32) for correct continued lubrication.

Our Technical Department will be glad to help.

Maximum standard strokes

Size 25	200 mm
Size 32 - 63	320 mm

Sections (cm²)

Size	25	32	40	50	63
Out stroke (cm ²)	5,28	8,09	13,09	20,28	32,68
In stroke (cm ²)	4,49	6,96	11,08	17,14	29,54

In order to calculate the theoretical force generated by the unit, both outstroke and instroke, it is necessary to use the following equation

$$\text{FORCE(Kg)} = \text{Surface (cm}^2\text{)} \times \text{Pressure(bar)}$$

It is also necessary to remember that the theoretical force must be reduced by 10-15% in order to account for the unit internal friction.

Maximum rod radial movement (°)

Size	25	32	40	50	63
Rod radial movement	±0.8	±0.7	±0.6	±0.5	±0.4

Maximum torque applicable on the piston rod (Nm):

Size	25	32	40	50	63
Maximum torque	0.8	1	1,3	1,8	2,1

The maximum torque values must also be accounted for while mounting accessories on the piston rod.

► **Basic version "1" female rod**

Ordering code
SIDE CONNECTION
1370.size.stroke.1 Magnetic chrome plated rod
1371.size.stroke.1 Magnetic stainless steel rod
1372.size.stroke.1 Non magnetic chrome plated rod
1373.size.stroke.1 Non magnetic stainless steel rod
REAR CONNECTION
1370.size.stroke.1.P Magnetic chrome plated rod
1371.size.stroke.1.P Magnetic stainless steel rod
1372.size.stroke.1.P Non magnetic chrome plated rod
1373.size.stroke.1.P Non magnetic stainless steel rod

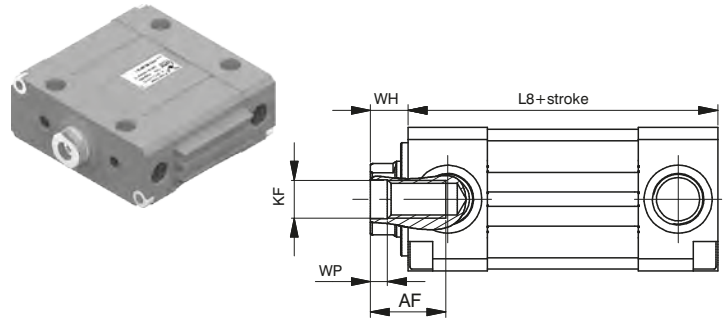

► **Basic version "2" male rod**

Ordering code
SIDE CONNECTION
1370.size.stroke.2 Magnetic chrome plated rod
1371.size.stroke.2 Magnetic stainless steel rod
1372.size.stroke.2 Non magnetic chrome plated rod
1373.size.stroke.2 Non magnetic stainless steel rod
REAR CONNECTION
1370.size.stroke.2.P Magnetic chrome plated rod
1371.size.stroke.2.P Magnetic stainless steel rod
1372.size.stroke.2.P Non magnetic chrome plated rod
1373.size.stroke.2.P Non magnetic stainless steel rod

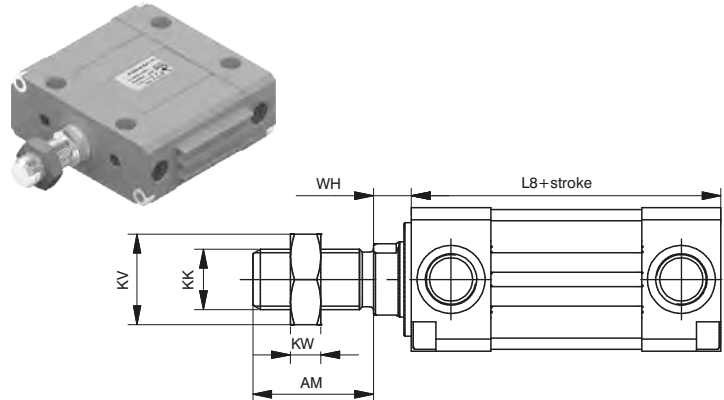

► **Female through rod cylinder version "3"**

Ordering code
1370.size.stroke.3 Magnetic chrome plated rod
1371.size.stroke.3 Magnetic stainless steel rod
1372.size.stroke.3 Non magnetic chrome plated rod
1373.size.stroke.3 Non magnetic stainless steel rod

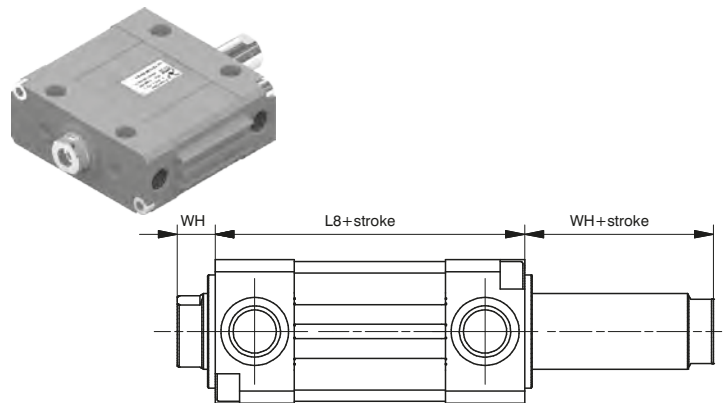

► **Male through rod cylinder version "4"**

Ordering code
1370.Size.stroke.4 Magnetic stelo cromato
1371.Size.stroke.4 Magnetic stelo inox
1372.Size.stroke.4 Non magnetico stelo cromato
1373.Size.stroke.4 Non magnetico stelo inox

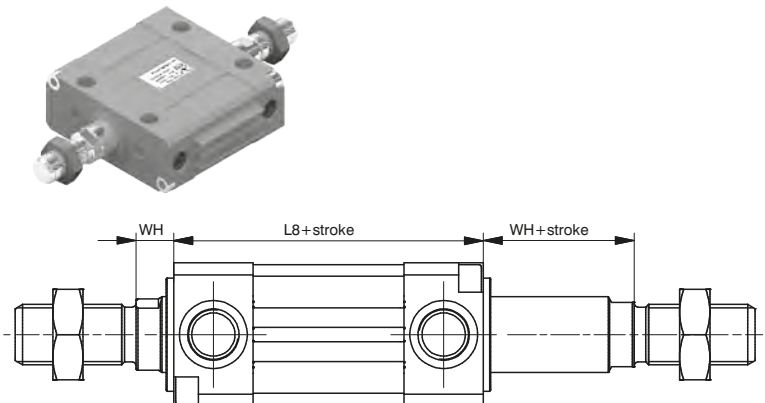

► **Variants**

Ordering code
137_size.stroke._K = Version with aluminium piston

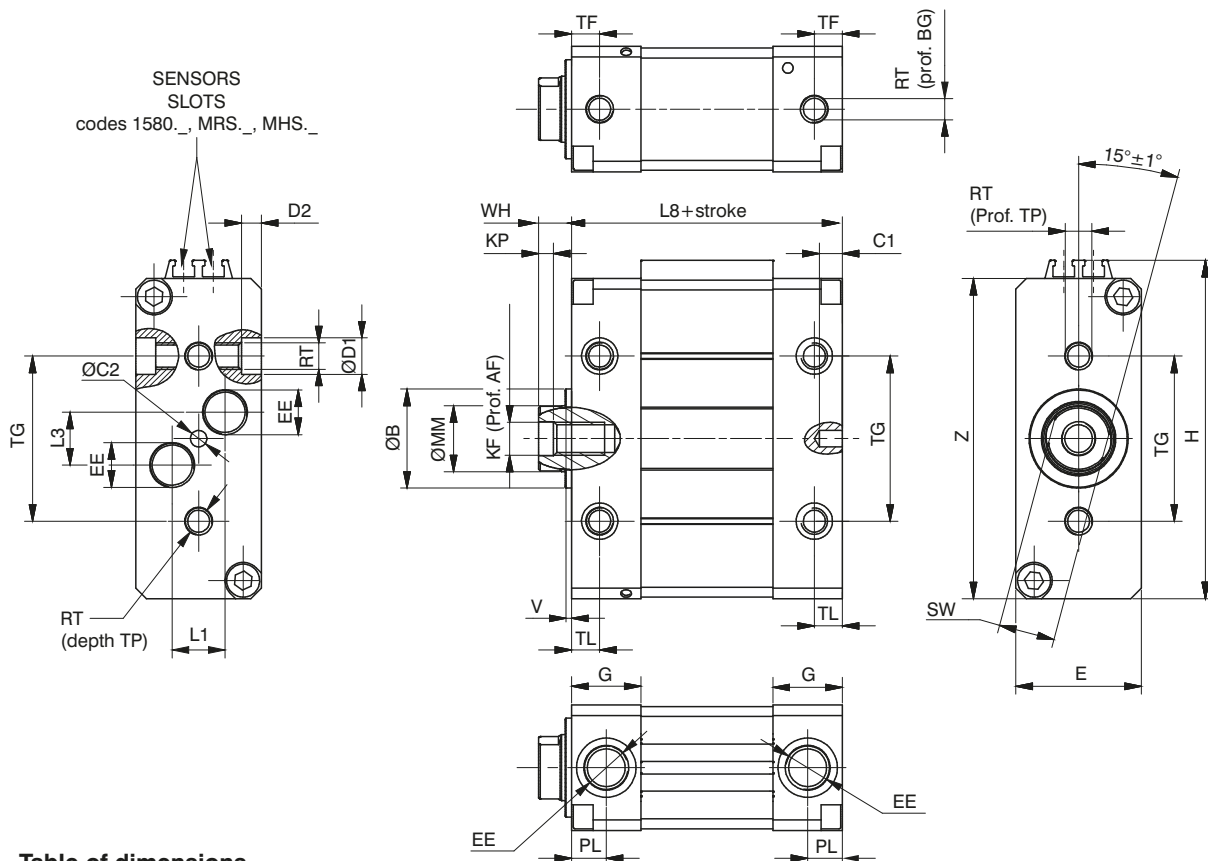

Table of dimensions

Size	25	32	40	50	63		
AM	22	22	24	32	32		
AF	12	14	16	20	20		
Ø B (h9)	16	20	25	30	30		
BG	8	9	9	12	14		
C1	7	7	7	7	7		
C2 (H9)	4	4	4	5	5		
Ø D1	8	10	10	11	15		
D2	4	4	5	6	6		
E	20	24	30	38	50		
EE	M5	G1/8"	G1/8"	G1/4"	G1/4"		
G	12	17	17	21	21		
H	56,5	65,5	82,5	102,5	127		
KF	M5	M6	M8	M10	M10		
KK	M10x1,25	M10x1,25	M12x1,25	M16x1,5	M16x1,5		
KP	2	2,5	3	4,5	4,5		
KV	17	17	19	24	24		
KW	6	6	7	8	8		
L1	6	7,5	7,5	16	19		
L3	10	14,5	14,5	16	21		
L8	62	72	76	82	82		
Ø MM	10	12	16	20	20		
PL	6,5	8,5	8,5	10,5	10,5		
RT	M5	M6	M6	M8	M10		
SW (H13)	8	10	13	17	17		
TF	5	8,5	8,5	8,5	8,5		
TG	25	32	40	50	60		
TL	5	8,5	8,5	8,5	8,5		
TP	8	9	9	12	14		
V	2	2	2	2	2		
VG	30	30	33	42	42		
WH	8	8	9	10	10		
Z	51	60	77	97	1215		
Weight g	Versions	1 stroke 0	180	285	482	848	1350
		2 stroke 0	203	309	520	929	1431
	every 10 mm		22	29	49	79	118
Weight g	Versions	3 stroke 0	195	314	534	959	1478
		4 stroke 0	242	362	610	1096	1615
	every 10 mm		28	38	65	103	143

► **Front and rear flange**

Ordering code
1370.Size.03



Plate which allows anchorage of the cylinder at a right angle to the plane. Mounted to the cylinder by screws.

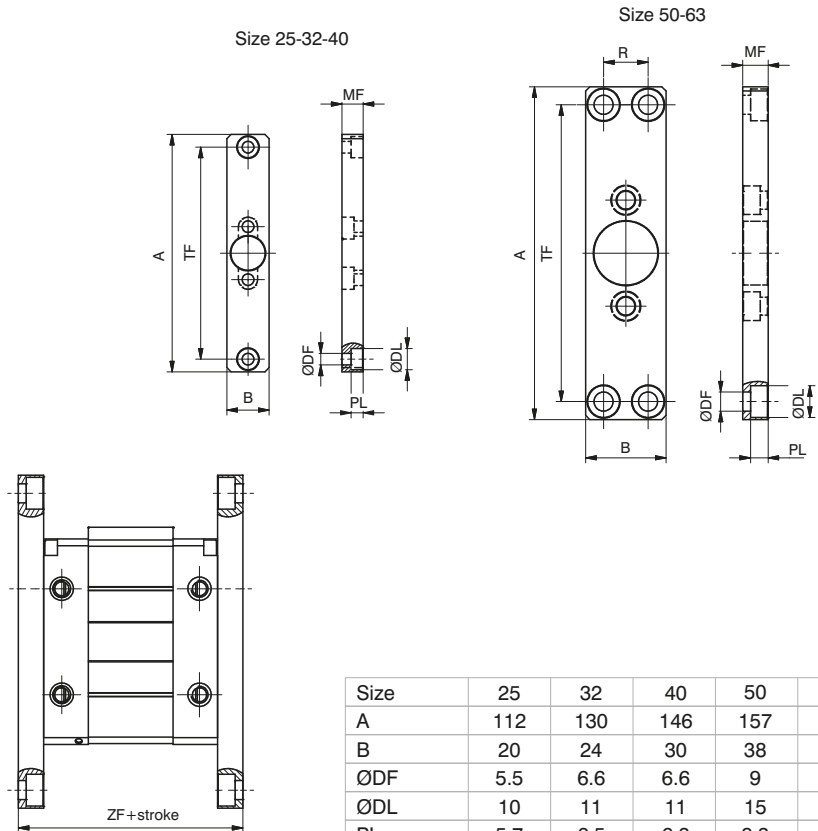

Size	25	32	40	50	63
A	112	130	146	157	157
B	20	24	30	38	50
ØDF	5.5	6.6	6.6	9	9
ØDL	10	11	11	15	15
PL	5.7	6.5	6.3	8.3	8.3
MF	10	10	10	12	15
R	/	/	/	21	33
TF	100	115	132	140	140
ZF	82	92	96	106	112

► **Foot bracket**

Ordering code
1370.Size.05/1F (n° 1 piece)



Brackets used to anchor the cylinder parallel to the mounting plane. Manufactured from steel with a rust proof protective treatment. Mounted to the cylinder end caps with bolts.

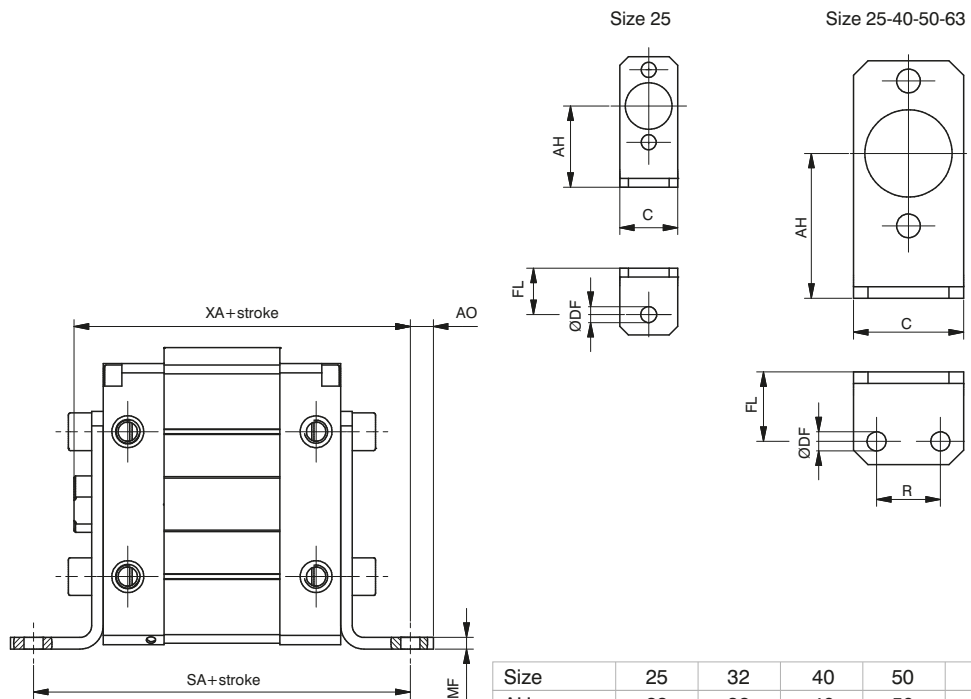

Size	25	32	40	50	63
AH	28	32	40	50	63
AO	7	5.5	7	8	10
C	20	24	30	38	50
ØDF	5.5	5.5	5.5	6.6	9
FL	16	18	20	24	27
MF	3	3	4	4	4
R	/	13	16	22	30
SA	94	108	116	130	136
XA	86	98	105	116	119

Rear male clevis

Ordering code

1370.Size.09/1F

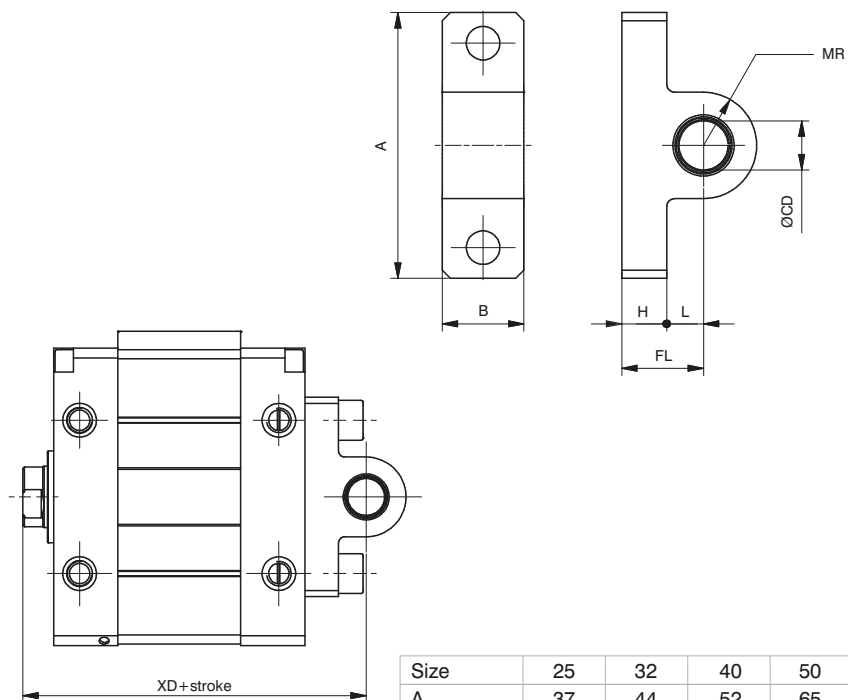

Size	25	32	40	50	63
A	37	44	52	65	78
B	9	10.5	10.5	20	25
ØCD (H7)	8	10	12	12	16
FL	14	15	18	20	24
H	6	9	9	11	11
L	8	6	9	9	13
MR	7.5	10	13	13	17
XD	84	95	103	112	116

This type of mounting allows anchorage of the cylinder either parallel or right angle to plane; the cylinder rod can oscillate and self-align as necessary when under load.

Rear clevis

Ordering code

1370.Size.09F

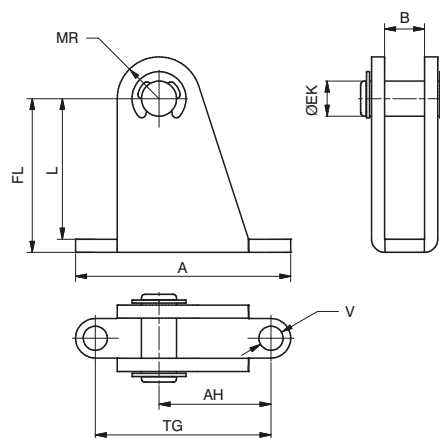

Size	25	32	40	50	63
A	49	60	60	46	60
AH	25.5	33	29.5	24	32
B	9.1	10.6	10.6	20.1	25.1
ØEK	8	10	12	12	16
FL	35	42	51	55	68
L	32	38	47	50	63
MR	9.5	11	14	14	18
TG	40	50	50	30	40
ØV	5.5	6.6	6.6	9	11

To be used in conjunction with 09/1 clevis.
 Similar to type 08 but includes a hinge pin.
 This type of mounting allows anchorage of the cylinder either parallel or right angle to plane; the cylinder rod can oscillate and self-align as necessary when under load.
 Manufactured from sheet metal with rust proof protective treatment.

Fork

Ordering code
1320.32.13F (for $\varnothing 25$ and $\varnothing 32$)
1320.40.13F (for $\varnothing 40$)
1320.50.13F (for $\varnothing 50$)
1320.63.13F (for $\varnothing 63$)

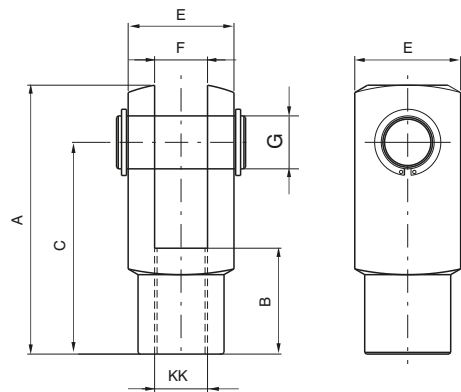

Fork with clips

Ordering code
1320.32.13/1F (for $\varnothing 25$ and $\varnothing 32$)
1320.40.13/1F (for $\varnothing 40$)
1320.50.13/1F (for $\varnothing 50$)
1320.63.13/1F (for $\varnothing 63$)

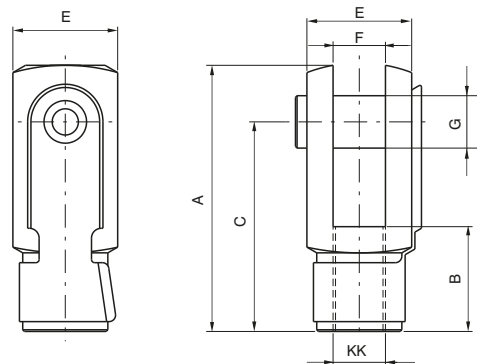

Nut

Ordering code
1320.32.18F (for $\varnothing 25$ and $\varnothing 32$)
1320.40.18F (for $\varnothing 40$)
1320.50.18F (for $\varnothing 50$)
1320.63.18F (for $\varnothing 63$)

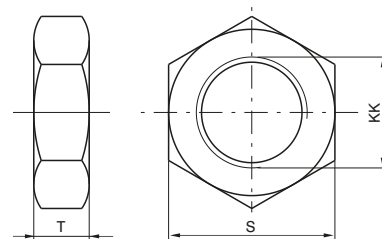

Fork:
Element that when screwed to the rod consents a regular functioning even when there are significant lateral forces as the connection point. Made of zinc-plated steel.

Nut:
Used to block the position of the fork.

Bore		25	32	40	50	63
A		52	52	62	83	83
B		20	20	24	32	32
C		40	40	48	64	64
E		20	20	24	32	32
F(B12)		10	10	12	16	16
G		10	10	12	16	16
S		17	17	19	24	24
T		6	6	7	8	8
KK		M10X1.25	M10X1.25	M12X1.25	M16X1.5	M16X1.5
Weight	fork	100	100	140	340	340
	nut	15	15	20	20	20

Ball joint

Ordering code

- 1320.32.32F**
(for ø25 and ø32)
- 1320.40.32F**
(for ø40)
- 1320.50.32F**
(for ø50)
- 1320.63.32F**
(for ø63)

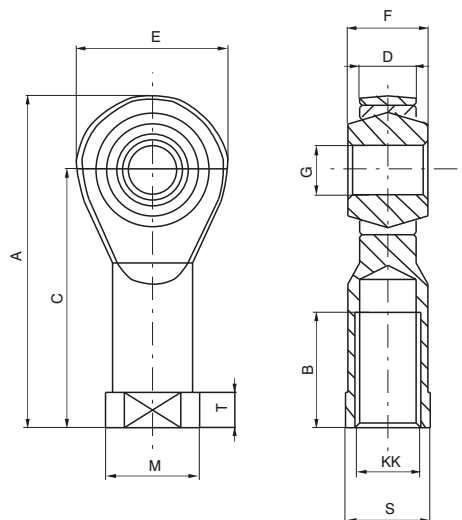

Bore	25	32	40	50	63
A	57	57	66	85	85
B	20	20	22	28	28
C	43	43	50	64	64
D (-0,1)	10.5	10.5	12	15	15
E	28	28	32	42	42
F	14	14	16	21	21
G (H 7)	10	10	12	16	16
KK	M10x1.25	M10x1.25	M12x1.25	M16x1.5	M16x1.5
M	19	19	22	27	27
S	17	17	19	22	22
T	6.5	6.5	6.5	8	8
Weight g	76	76	110	220	220

Self-aligning joint

Ordering code

- 1320.32.33F**
(for ø25 and ø32)
- 1320.40.33F**
(for ø40)
- 1320.50.33F**
(for ø50)
- 1320.63.33F**
(for ø63)

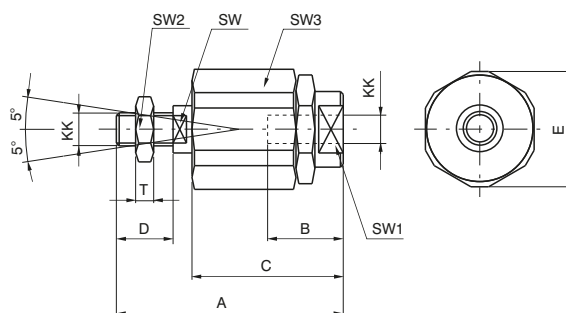

Bore	25	32	40	50	63
A	71	71	75	103	103
B	20	20	20	32	32
C	46	46	46	63	63
D	20	20	24	32	32
E	32	32	32	45	45
KK	M10x1,25	M10x1,25	M12x1,25	M16x1,5	M16x1,5
SW	12	12	12	20	20
SW1	19	19	19	27	27
SW2	17	17	19	24	24
SW3	30	30	30	41	41
T	6	6	7	8	8
Weight g	220	220	230	660	660